

QY70

Crawler Crane Technical Manual

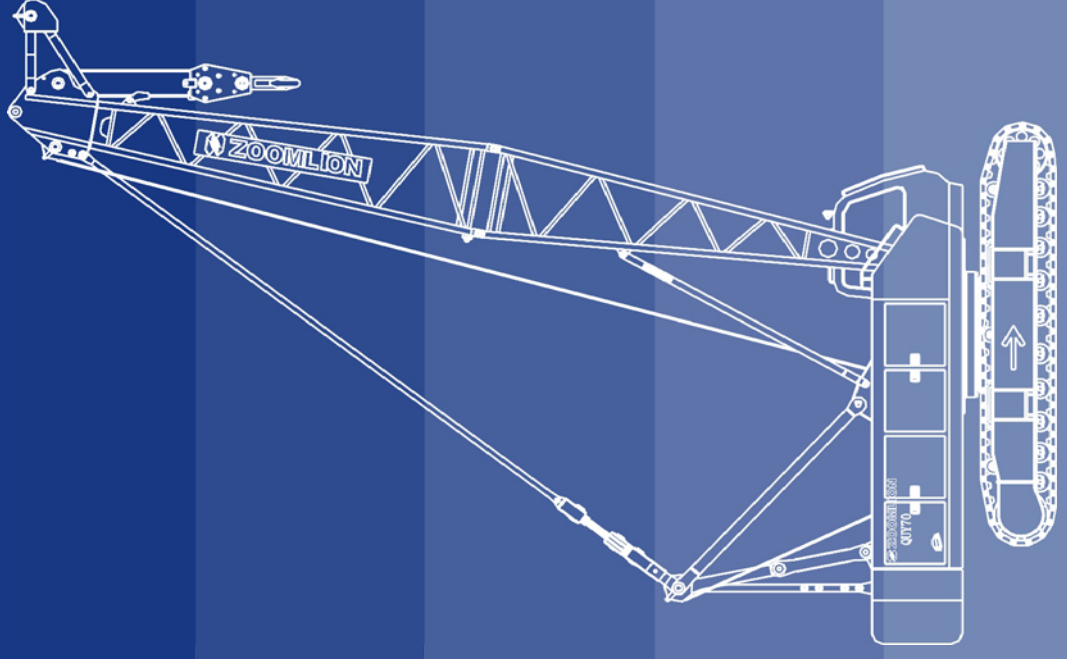

I. Overall dimensions and main parameters

1) Overall dimensions of basic machine	01
2) Main technical parameters	02
3) Transport dimensions and weights of main components	03

II. Technical instruction

4) Boom system	04
5) Working mechanism	04
6) Crane system	05
7) Safety equipment	06
8) Operator's cab	06
9) Load hook	06

III. Self-assembly & dismantling function 07

IV. Lifting capacity

10) Lifting performance on S boom	09
11) Lifting performance on SF boom	12

I . Overall dimensions and main parameters

1.Overall dimensions of basic machine

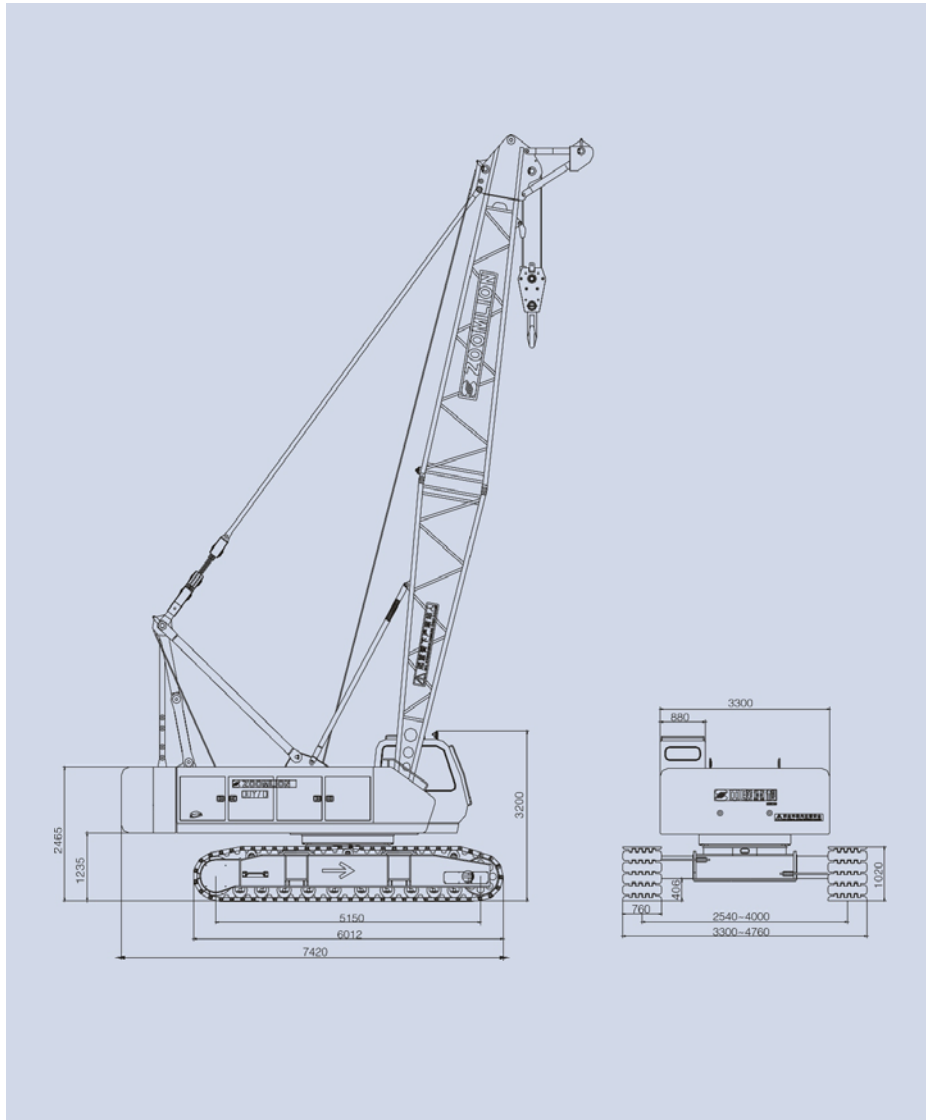

2.Main technical parameters

Item	Unit	Value	Remarks	
Max. lifting capacity × radius	t × m	70 × 3.8		
Deadweight with basic boom	t	61		
Main boom length	m	12~57		
Fixed jib length	m	6~18		
Max. lifting capacity on fixed jib	t	6.4		
Fixed jib angle	°	10,30		
Max. length of main boom with fixed jib	m	42 + 18		
Single rope speed of winches	Hoisting winch 1	m/min	120	The 4 th rope layer
	Hoisting winch 2	m/min	120	The 4 th rope layer
	Derricking winch	m/min	45	The 4 th rope layer
Slewing speed	rpm	0~2.4		
Traveling speed	km/h	0~1.35		
Gradeability	%	30		
Ground pressure	MPa	0.074		
Overall dimensions (L × W × H)	mm	12400 × 3300 × 3200	With A-frame and boom pivot section	
Engine	Weichai			
	Rated power/ rotational speed	kW/rpm	175/2200	
	Max. output torque/ rotational speed	Nm/rpm	1000/1400 ~ 1600	
	Exhaust emission standard		EU Stage II / III	
	USA Cummins			
	Rated power/ rotational speed	kW/rpm	153/1800	
Max. output torque/ rotational speed	Nm/rpm	929/1300		
Exhaust emission standard		TIER3/EU stage III		
Distance between track center × crawler contact length × crawler width	mm	2540 × 5150 × 1020	Crawler carrier retracted	
Distance between track center × crawler contact length × crawler width	mm	4000 × 5150 × 1020	Crawler carrier extended	

3. Transport dimensions and weights of main components

Unit: mm

Transport weight of basic machine: 40t Number: 1 Width: 3300mm

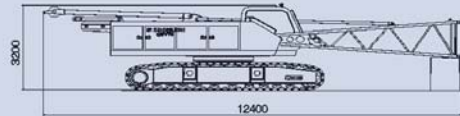

Counterweight plate: 12t Number: 1 Height: 1230mm



Counterweight plate: 9.87t Number: 1 Height: 1230mm

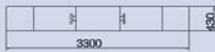

Load hook (70T) : 0.76t Number: 1 Width: 700mm

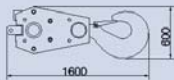

Load hook (30T) : 0.38t Number: 1 Width: 370mm

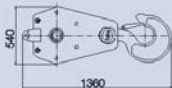

Load hook (6T) : 0.18t Number: 1 Width: 320mm

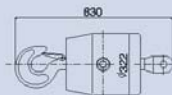

Main boom head (with tip boom) : 0.95t Number: 1 Width: 1450

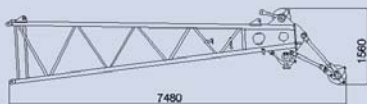

3m main boom intermediate section: 0.29t Number: 1 Width: 1450mm



6m main boom intermediate section: 0.53t Number: 1 Width: 1450mm

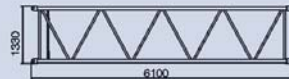

9m main boom intermediate section: 0.63t Number: 4 Width: 1450mm



Fixed jib pivot section (with FA-frame and tilting-back support of fixed jib): 0.58t Number: 1 Width: 560mm

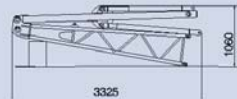

6m fixed jib intermediate section: 0.161t Number: 2 Width: 560mm



Fixed jib head: 0.25t Number: 1 Width: 560mm

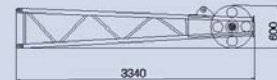

II . Technical instruction

4. Boom system

The lattice boom is made of high-strength steel pipes.

Main boom (S boom)

S- main boom: 12 ~ 57m

Main boom intermediate section: 3m, 6m and 9m

Number of main boom intermediate section for S boom

Main boom length (m)	Number of main boom intermediate section		
	3m	6m	9m
15	1	0	0
18	2	0	0
21	1	1	0
24	2	1	0
27	1	2	0
30	1	1	1
33	2	1	1
36	1	2	1
39	1	1	2
42	2	1	2
45	1	2	2
48	1	1	3
51	2	1	3
54	1	2	3
57	1	1	4

Main boom with fixed jib (SF boom)

S- main boom: 30m~42m

F- fixed jib: 6~18m

Fixed jib intermediate section: 6m

Max. length of main boom with fixed jib: 42+18m

5. Working mechanism

Hoisting winch 1

The hoisting winch 1 is composed of concealed axial piston hydraulic motor, balance valve, reducer, normally closed brake as well as wire rope. It is controllable independently.

The hoisting winch 1 has two kinds of hoisting speed, which can improve the working efficiency dramatically.

Hoisting winch 1	Rope diameter	20mm
	Rope length	240m
	Single rope speed (on the 4 th rope layer)	0 ~ 120m/min
	Single rope force	69kN

Hoisting winch 2

The hoisting winch 2 is composed of concealed axial piston hydraulic motor, balance valve, reducer, normally closed brake as well as wire rope. And it is controllable independently.

The hoisting winch 2 has two kinds of hoisting speed, which can improve the working efficiency dramatically.

Hoisting winch 2	Rope diameter	20mm
	Rope length	160m
	Single rope speed (on the 4 th rope layer)	0 ~ 120m/min
	Single rope force	69kN

Derricking winch

The derricking winch is composed of concealed axial piston hydraulic motor, balance valve, reducer and normally closed brake, pulley block as well as wire rope. And it is controllable independently.

It is also equipped with a ratchet locking device to prevent the derricking winch from rotating during long time parking.

Derricking winch	Rope diameter	20mm
	Rope length	120m
	Single rope speed (on the 4 th rope layer)	0 ~ 45m/min
	Single rope force	71kN

Slewing mechanism

The slewing mechanism consists of concealed axial piston hydraulic motor, gear reducer, slewing brake valve, brake and pinion gear as well as slewing ring. The superstructure can realize 360° continuous rotation via slewing ring which is driven by pinion gear.

The internal-gear slewing ring and slewing reducer built in the crane, are of strong load-carrying capacity and high accuracy, which can ensure stable and accurate slewing motion.

Infinitely variable speed from 0 to 2.4 r/min

The slewing mechanism can be locked by two mechanical locking devices in the front of slewing table.

Traveling mechanism

The traveling mechanism is fitted with two hydraulic motors and two traveling reducers. The hydraulic motor and balance valve are all imported. Using control levers, the traveling movements can be controlled, such as traveling straight ahead/backwards, turning with a crawler, differential steering, turning on spot, traveling with load. This kind of design enables crane to have high maneuverability.

Traveling speed: 0~1.35km/h (it is assumed that the crane is on the firm and even ground and the main boom is not attached with load).

Gradeability: 30%

The tension degree of crawler can be adjusted by jack quickly and conveniently.

A-frame mechanism

A-frame mechanism consists of A-frame, A-frame anchoring rods and anchoring rod for self-assembly/dismantling and so on. It is mainly used for assembly, dismantling and conversion of crane. After A-frame is tilted backwards, the counterweight anchoring rods can be connected to A-frame anchoring rods, thus A-frame can be used to attach and remove the counterweight.

The A-frame must be laid down on the rear part of slewing table during transport

Counterweight and its fitting&removal mechanism

Counterweight fitting&removal mechanism is composed of counterweight anchoring rod, rear anchoring rod of A-frame front support of A-frame derricking pulley block, main boom pivot section and tilting-back support of main boom.

For QUY50 crawler crane, the counterweight can be fitted and removed by crane itself.

Crawler carrier extending/retracting mechanism

The crawler carrier extending/retracting mechanism consists of outrigger, crawler carrier extending/retracting cylinder, crawler carrier, anchoring rods and inserting pin etc.. The undercarriage control lever in the front of undercarriage centre section can be used to switch the crawler traveling movements over to extending/retracting of crawler carrier.

The extending/retracting of crawler carrier is controlled by control lever in operator's cab.

6. Crane system

Hydraulic system

The hydraulic system is composed of main pump, control valve, hydraulic motor, hydraulic oil tank, and oil cooler and so on.

International advanced pump-control system is applied in the hydraulic system. Main hydraulic elements such as traveling motor, imported as options, are of high energy-saving, great reliability and long service life.

Main hydraulic pump: domestically made piston pump, driven by engine.

Slewing pump is imported.

Auxiliary mechanism is supplied oil by gear pump.

Main control valve: electro-hydraulic pilot valve

Main circuit control way: main variable displacement pump + main changeover valve, controlled by two control levers.

Hydraulic oil tank: 700L

Oil cooler: it is an aluminium cooler, and the cooler fan is driven by a motor.

Overflow valve

The overflow valve fitted in hydraulic system can restrain the pressure in the oil circuit from rising irregularly, thus protect such hydraulic elements as hydraulic oil pump and hydraulic motor against damage and prevent the hydraulic system from being overloaded.

Electrical system

24VDC, negative ground, two batteries of 165AH each

The electrical system of machine includes power source, engine start, engine shutdown, indicator light, warning device, illumination device, fan, wiper, horn, hoisting limiter, hydraulic oil cooling fan, digital display system, PLC controller, engine preheating device, safety equipment etc. which not only ensure safe operation of the crane, but also provide a good working environment. The crane adopts CAN bus control technology, which connects the engine, PLC controller and digital display efficiently, possessing fault detecting and self-diagnosis function.

Crane engine

6-cylinder Weichai (Cummins) diesel engine, turbocharger, watercooled

Fuel tank has a great capacity of 300L, which can ensure long time working of engine.

Exhaust emissions according to EU Stage II / III (TIER3)

Digital display system

The 11-inch LCD, having Chinese and English language versions, can show various data collected by PLC controller such as engine speed, water temperature, engine oil pressure, pressure of hydraulic pump, pressure of main motor, crane inclination, wind speed and operating hours of engine and so on. In this way, it can monitor the working state of crane at any time. When abnormal conditions occur, the system will send out red or yellow warning signal.

Monitoring system (optional)

2 video cameras: respectively monitor the working condition of crane winches and rear side of the crane
Display: switch between the monitoring screens via press-key.

Remote monitoring system GPS (optional)

Application of GPS enables such functions to be available as global positioning, GPRS data transmitting, working condition monitoring, remote fault diagnosing.

7. Safety equipment

Load moment limiter

It is composed of digital LCD, CPU, signal converter, sensor and so on. When actual load moment reaches 90% of the maximum permissible load moment, the warning light will light up and the buzzer will sound. When actual load moment approaches the maximum permissible load moment, the dangerous movements will be switched off automatically so as to avoid accidents caused by overloading of crane, and thus ensure normal and safe crane operation.

The following data can be shown on the digital LCD:

Moment ratio

Main boom angle

Main boom length

Working radius

Actual load

Maximum permissible lifting load

Maximum permissible lifting height

Hoisting limiter

Device to prevent any specified upper limitation of the load lifting attachment from being exceeded.

If the load hook comes into contact with hoisting limit switch weight during its upward movement, the hoisting limit switch is triggered, the buzzer sounds, and the crane movement "spool up winch" is switched off.

Angle indicator

It is fitted at the lower rear end of boom pivot section (i.e. on the right side of the operator's cab). The operator can clearly see the boom angle in the cab.

Derricking limiter

Device, constituted by load moment limiter and limit switch, to prevent derricking motions of main boom beyond specified limits

Crane inclinometer

An electronic inclinometer to indicate the "leveled position" of the crane

Lowering limiter

Device to ensure that three windings of rope on the hoist drum are maintained at all times during operation

When there are only 3 windings of rope left on the drum, the lowering limit switch is triggered, the buzzer sounds, and the crane movement "reel off winch" is switched off.

Anemometer

An electronic device to indicate the actual wind speed to the crane operator

Safety catch

Device to protect the lifted load from jumping out from the hook

Tilting back support for main boom

The spring-loaded tilting-back steel support, mounted on the main boom pivot section, is used to prevent the main boom from tilting backwards.

Ratchet locking device for derricking winch

Device to prevent the derricking winch from rotating during long time parking

Emergency shut-down button

Allow all crane movements and electrical control system to be cut off quickly in a dangerous situation.

Tricolor warning light

The warning light, by showing red, yellow and green three colors, can indicate loading status synchronously. The green color means the load ratio is less than 90%, the yellow color means the load ratio is between 90% and 100%, and the red color means that the load ratio has exceeded 100% and the crane is overloaded.

8. Operator's cab

Spacious, comfortable and all-steel construction cab, equipped with sun visor, adjustable seat, wiper, electric control levers, display of load moment limiter, digital display, switches on auxiliary control box, air conditioning, fan, lighting lamp, Radio (CD player or DVD player), cigarette lighter, fire extinguisher etc.

9. Load Hook

The following types of load hook can be selected:

70t load hook: 6 pulleys

30t load hook: 2 pulleys

6t load hook: without pulley

III. Self-assembly & dismantling function

Take the self-assembly of crane in SF boom configuration as an example

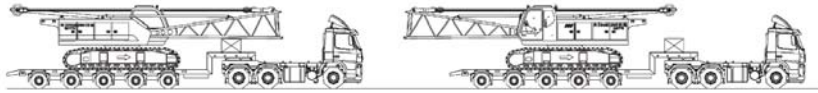

Unloading of basic machine

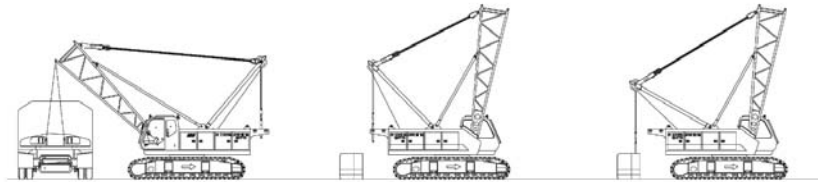

Unloading and assembly of counterweight

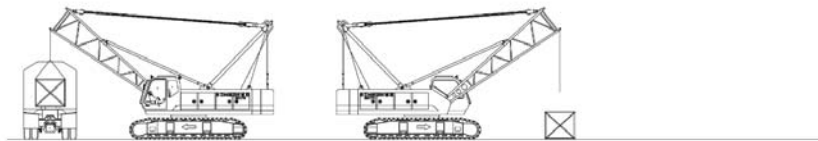

Unloading of boom frame

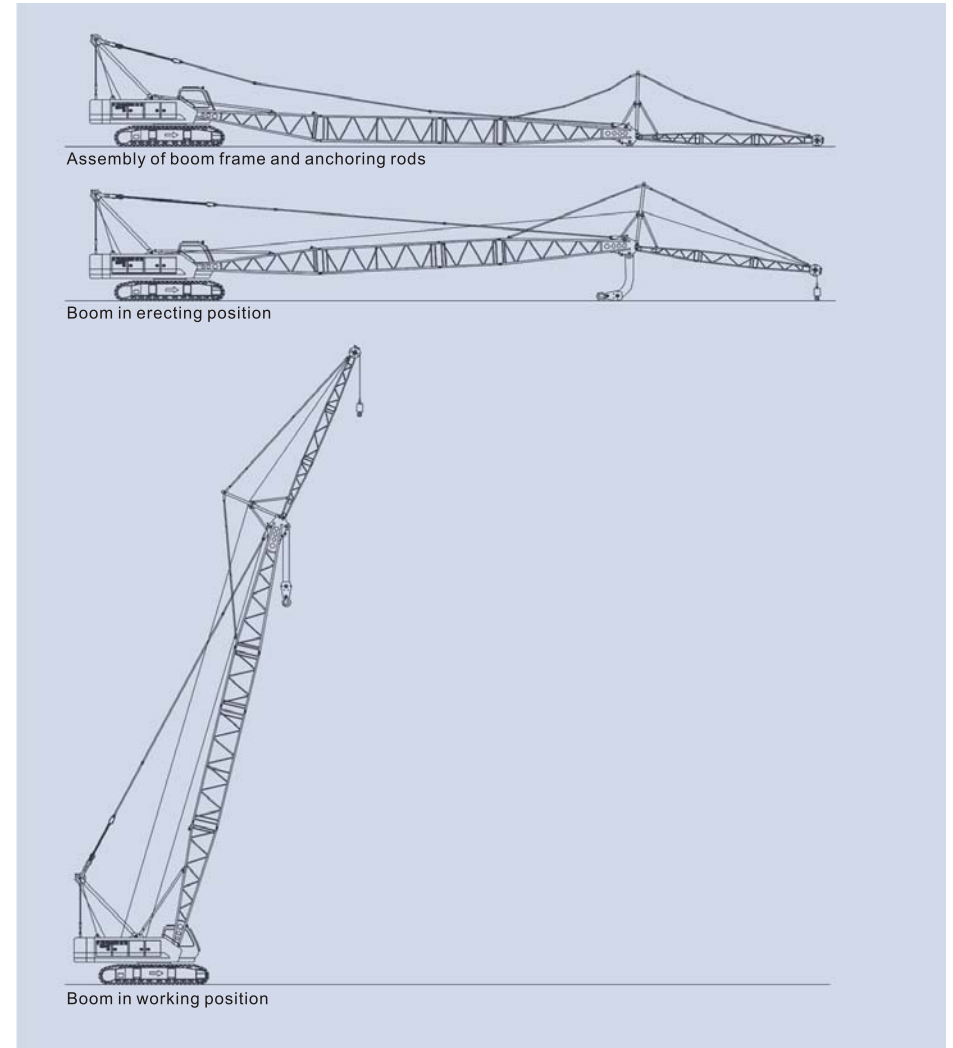

IV. Lifting capacity

10. Lifting performance on S boom

Lifting height on S boom

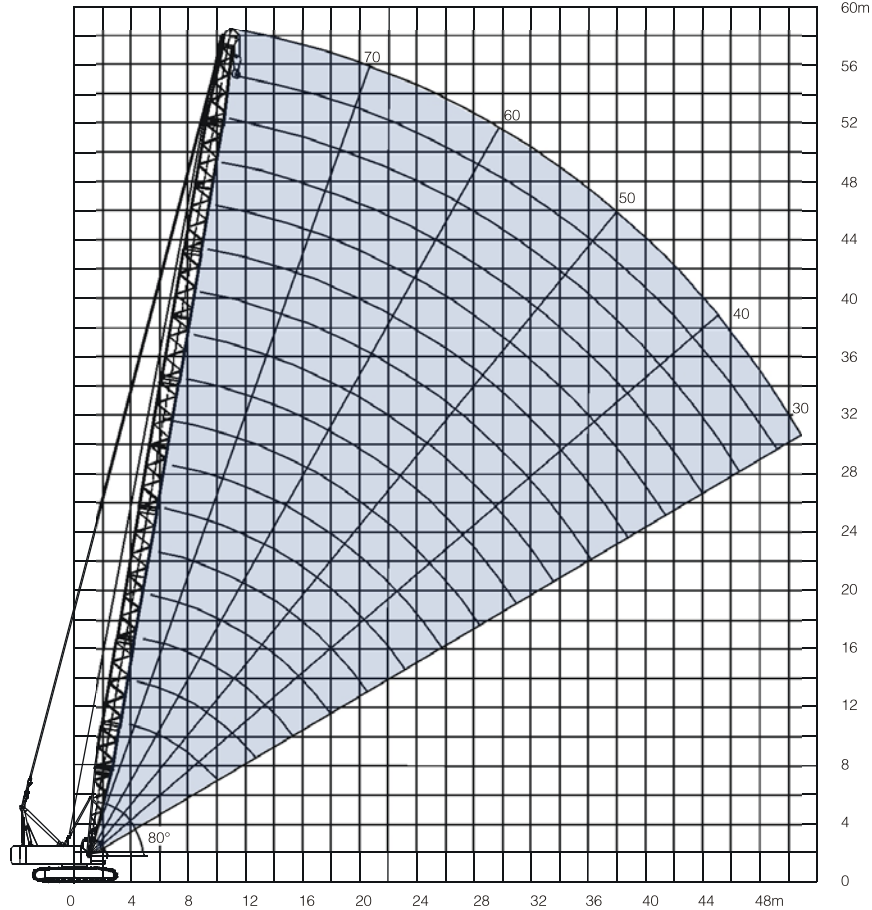

Lifting capacity on S boom(1)

Length of S(m)	12	15	18	21	24	27	30	33
Reeving Radius (m)	12	12	10	8	8	6	6	6
3.8	70							
4	65	65	58.2/4.1	51.2/4.6				
5	53.6	52.3	51	49.8	44.2/5.2	37/5.7		
6	40.5	40.1	39.3	38.5	37.7	36.9	34/6.2	30.4/6.7
7	32.1	32	31.8	31.2	30.6	30.1	29.5	28.9
8	26.6	26.5	26.4	26.2	25.8	25.3	24.8	24.3
9	22.6	22.5	22.4	22.3	22.2	21.8	21.4	21
10	19.7	19.5	19.4	19.3	19.2	19.1	18.7	18.4
12		15.4	15.3	15.1	15	14.9	14.8	14.6
14		12.6	12.5	12.4	12.2	12.1	12	11.9
16			10.5	10.4	10.2	10.1	10	9.9
19				8.3	8.1	8	7.9	7.8
20					7.6	7.5	7.3	7.2
22					6.7	6.5	6.4	6.3
24						5.8	5.7	5.5
26							5	4.9
28								4.4
29								4.1

11. Lifting performance on SF boom

Lifting capacity on S boom(2)

Length of S(m) Reeving Radius (m)	36	39	42	45	48	51	54	57
7	27.1/7.3	24.3/7.8						
8	23.9	23.4	21.9/8.3	19.9/8.8				
9	20.6	20.2	19.8	19.4	18.1/9.3	14.6/9.9		
10	18	17.7	17.3	17	16.6	14.6	14.6/10.4	13.7/10.9
12	14.3	14	13.7	13.5	13.2	13.3	13.1	12.8
14	11.7	11.5	11.3	11	10.8	10.9	10.7	10.5
16	9.8	9.6	9.5	9.2	9	9.1	8.9	8.7
19	7.6	7.5	7.4	7.3	7.7	7	6.9	6.8
20	7.1	7	6.8	6.7	7.1	6.5	6.3	6.2
22	6.2	6	5.9	5.8	6.6	5.5	5.4	5.3
24	5.4	5.3	5.1	5	5.7	4.8	4.6	4.5
26	4.8	4.6	4.5	4.4	4.9	4.1	4	3.9
28	4.2	4.1	4	3.9	4.3	3.6	3.5	3.3
29	4	3.9	3.7	3.6	3.7	3.4	3.2	3.1
30	3.8	3.6	3.5	3.4	3.5	3.1	3	2.9
32	3.4	3.2	3.1	3	3.3	2.7	2.6	2.5
34		2.9	2.8	2.6	2.9	2.4	2.3	2.1
36			2.5	2.3	2.5	2.1	1.9	1.8
37			2.3	2.2	2.2	1.9	1.8	1.7
38				2.1	2.1	1.8	1.7	1.5
39				1.9	1.9	1.7	1.5	1.4
40					1.8	1.6	1.4	1.3
42					1.7	1.3	1.2	1.1

Note:

1. The lifting capacity given in the above chart contains the weight of load hook and weight of wire rope between boom head and load hook.
2. When tip boom is used to lift the load, the lifting capacity on tip boom is the same as that on main boom of same length in the same working radius.

Lifting height on SF boom(1)

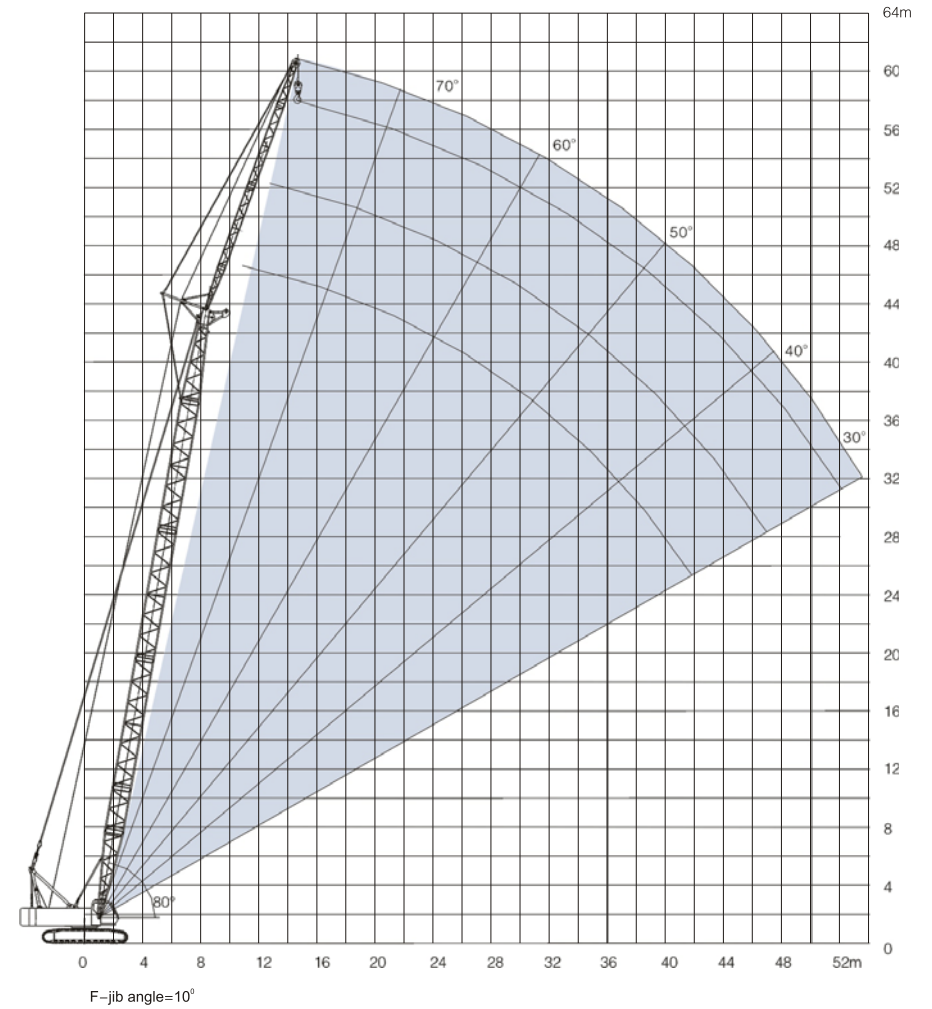

Lifting height on SF boom (2)

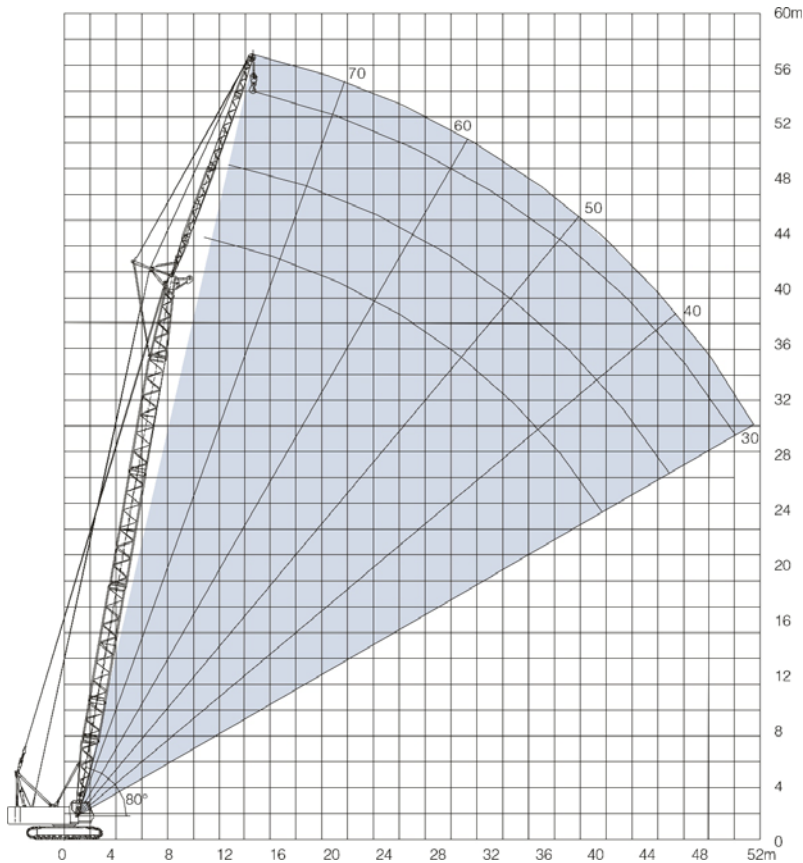

F-jib angle=30°

Lifting capacity on SF boom(1)

Length of S (m)	30						33					
	6		12		18		6		12		18	
Length of F (m)	F-jib angle		F-jib angle		F-jib angle		F-jib angle		F-jib angle		F-jib angle	
Radius (m)	10°	30°	10°	30°	10°	30°	10°	30°	10°	30°	10°	30°
8	6.4/8.3						6.4/8.8					
10	6.4	6.4/10.1	6.4/10.3				6.4	6.4/10.6	6.4/10.8			
12	6.4	6.4	6.4	6.4/13.9	5.0/12.4		6.4	6.4	6.4		4.9/12.9	
14	6.4	6.4	6.4	6.4	4.8		6.4	6.4	6.4	6.4/14.4	4.9	
16	6.4	6.4	6.4	6.4	4.8	4.5/17.8	6.4	6.4	6.4	6.4	4.8	
18	6.4	6.4	6.4	6.4	4.7	4.5	6.4	6.4	6.4	6.4	4.8	4.4/18.3
20	6.4	6.4	6.4	6.4	4.6	4.3	6.4	6.4	6.4	6.4	4.6	4.3
22	6.4	6.4	6.4	6.4	4.5	4.3	6.3	6.3	6.4	6.4	4.5	4.3
24	5.6	5.6	5.9	5.9	4.5	4.3	5.5	5.5	5.6	5.8	4.5	4.3
26	4.9	4.9	5.2	5.2	4.4	4.2	4.8	4.8	5	5.1	4.5	4.2
28	4.4	4.4	4.6	4.6	4.4	4.2	4.3	4.3	4.4	4.5	4.4	4.2
30	3.9	3.9	4.1	4.1	4.2	4.2	3.8	3.8	3.9	4.0	4	4.2
32	3.5	3.5	3.7	3.7	3.6	3.9	3.4	3.4	3.5	3.6	3.6	3.8
34			3.3	3.3	3.4	3.5	3.0	3.0	3.2	3.2	3.3	3.4
36			3	3	3.1	3.1	2.6	2.6	2.9	2.9	2.9	3.0
38			2.6	2.6	2.8	2.8			2.5	2.5	2.6	2.7
40					2.5	2.5			2.3	2.3	2.4	2.4
42					2.3	2.3			2.0	2.0	2.2	2.2
44					2.0	2.0					1.9	1.9

Lifting capacity on SF boom(2)

Length of S (m)	36						39					
	6		12		18		6		12		18	
	10°	30°	10°	30°	10°	30°	10°	30°	10°	30°	10°	30°
8	6.4/9.3						6.4/9.8		6.4/11.9			
10	6.4	6.4/11.1	6.4/11.4				6.4	6.4/11.6	6.4			
12	6.4	6.4	6.4		4.9/13.4		6.4	6.4	6.4		4.9/13.9	
14	6.4	6.4	6.4	6.4/15	4.9		6.4	6.4	6.4	6.4/15.5	4.9	
16	6.4	6.4	6.4	6.4	4.8		6.4	6.4	6.4	6.4	4.8	
18	6.4	6.4	6.4	6.4	4.8	4.5/18.8	6.4	6.4	6.4	6.4	4.8	4.5/19.3
20	6.4	6.4	6.4	6.4	4.7	4.4	6.4	6.4	6.4	6.4	4.7	4.5
22	6.1	6.2	6.3	6.4	4.5	4.3	6	6.1	6.2	6.4	4.6	4.3
24	5.3	5.4	5.5	5.7	4.5	4.3	5.2	5.3	5.4	5.6	4.6	4.3
26	4.7	4.7	4.9	5.0	4.5	4.3	4.6	4.6	4.7	4.9	4.5	4.3
28	4.1	4.1	4.3	4.4	4.3	4.2	4	4.0	4.2	4.3	4.2	4.2
30	3.7	3.7	3.8	3.9	3.9	4.1	3.5	3.5	3.7	3.8	3.8	4.0
32	3.2	3.2	3.4	3.5	3.5	3.7	3.1	3.1	3.3	3.4	3.4	3.6
34	2.9	2.9	3	3.1	3.1	3.3	2.8	2.8	2.9	3.0	3	3.2
36	2.5	2.5	2.7	2.8	2.8	2.9	2.4	2.4	2.6	2.6	2.7	2.8
38	2.2	2.2	2.4	2.4	2.5	2.6	2.1	2.1	2.3	2.3	2.4	2.5
40			2.2	2.2	2.3	2.3	1.9	1.9	2.1	2.1	2.1	2.2
42			2	2	2	2.1	1.6	1.6	1.8	1.8	1.9	2.0
44			1.7	1.7	1.8	1.8			1.6	1.6	1.7	1.8
46					1.6	1.6			1.4	1.4	1.5	1.5
48					1.4	1.4					1.3	1.3
50					1.2	1.2					1.2	1.2
52											1	1.0

Lifting capacity on SF boom(3)

Length of S (m)	42					
	6		12		18	
	10°	30°	10°	30°	10°	30°
10	6.4/10.3					
12	6.4	6.4/12.2	6.4/12.4			
14	6.4	6.4	6.4		4.9/14.4	
16	6.4	6.4	6.4	6.4	4.9	
18	6.4	6.4	6.4	6.4	4.8	4.5/19.9
20	6.4	6.4	6.4	6.4	4.7	4.5
22	5.9	6.1	6.1	6.3	4.7	4.3
24	5.1	5.2	5.3	5.5	4.6	4.3
26	4.4	4.5	4.6	4.8	4.6	4.3
28	3.9	4	4.1	4.2	4.2	4.3
30	3.4	3.4	3.6	3.7	3.7	3.9
32	3	3.0	3.2	3.3	3.3	3.3
34	2.6	2.6	2.8	2.9	2.9	3.1
36	2.3	2.3	2.5	2.5	2.6	2.7
38	2.1	2.0	2.2	2.2	2.3	2.4
40	1.8	1.8	1.9	2.0	2	2.1
42	1.5	1.5	1.7	1.7	1.8	1.9
44	1.3	1.3	1.5	1.5	1.6	1.7
46			1.3	1.3	1.4	1.4
48			1.1	1.1	1.2	1.2
50					1.1	1.1
52					0.9	0.9
54					0.8	0.8